

PENWAY

Air Separator With Strainer

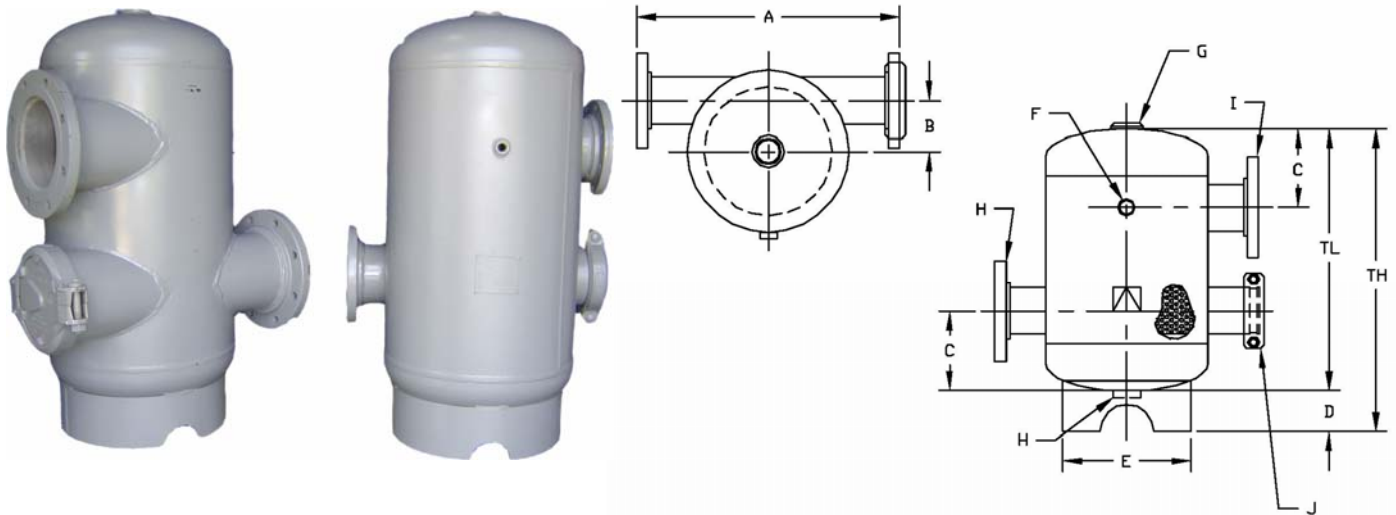

Description: Air Separator used for removal of entrained air in hydronic and pumping systems

Specifications:

- Built to ASME Code Section VIII, National Board Registered
- Carbon Steel
- Basing Support
- 150 PSI Working Pressure @ 400 °F
- Grey Primer
- Item "J" has grooved coupling & cap

DESCRIPTION		DIMENSIONS (INCHES)							OPENINGS					
PART #	DIA	TL	TH	A	B	C	D	E	F	G	H	I	J	WT
ASW002	12	19 ½	22 ½	16 5/8	4 5/16	5 ½	3	9 ½	½	1 ¼	1	2 NPT	2	45
ASW0025	12	21	23 ½	16 5/8	4 1/16	6 ¼	2 ½	9 ½	½	1 ¼	1	2 ½ NPT	2 ½	42
ASW003	12	20 ½	23 ½	19 ¾	3 ¾	6 ¼	2 ½	9 ½	½	1 ¼	1	3 FLG	3	52
ASW004	14	29	32	21 ¾	4 ¼	9 1/8	3	11 ½	½	1 ½	2	4 FLG	4	94
ASW005	14	29	32	21 ¾	3 ¾	9 1/8	3	11 ½	½	1 ½	2	5 FLG	5	116
ASW006	20	41	44	28	6 ¼	13 ¼	3	18	½	2	2	6 FLG	6	201
ASW008	20	41	44	28	5 3/16	13 ¼	3	18	½	2	2	8 FLG	8	296
ASW010	30	58	60 ½	41	9 1/8	19	2 ½	24	½	2	2	10 FLG	10	560
ASW012	30	58	60 ½	41	8 1/8	19	2 ½	24	½	2	2	12 FLG	12	870
ASW014	36	75 ½	78	46 3/8	10 3/16	22	2 ½	30	½	2	2	14 FLG	14	1220
ASW016	48	100	108	60	12 ½	30	8	39	½	2	2	16 FLG	16	2700
ASW018	54	116	124	66	13 5/8	33	8	45	½	2	2 ½	18 FLG	18	3000
ASW020	60	130	138	72	16	35	8	49	½	2	2 ½	20 FLG	20	4000
ASW024	72	152	160	84	19	40	8	55	½	2	2 ½	24 FLG	24	6900