

# PENWAY

## Epoxy Lined Water Storage Tanks

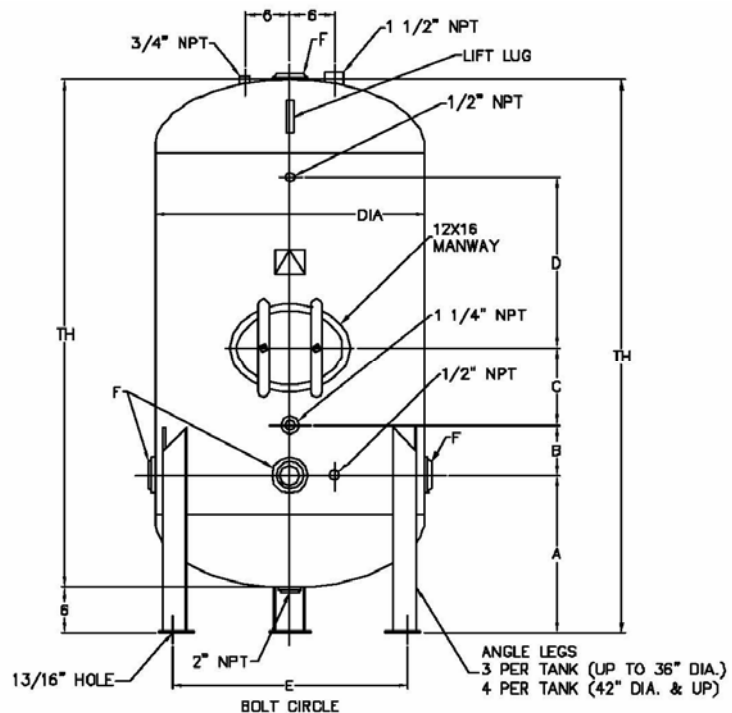

**Description:** Vertical Water Storage Tanks for Potable Water Storage

**Specifications:** Built to ASME Code Section VIII  
National Board Certification  
Carbon Steel  
150PSI @ 200°F  
Angle Leg Support  
Grey Primer

PART #	DESCRIPTION				DIMENSIONS (INCHES)					OPENINGS	WT. (LBS)
	GALLONS	DIA	TL	TH	A	B	C	D	E	F	
A8140	140	24	75	81	16 7/8	10	16 5/8	28 1/8	24	2 1/2 NPT	333
A8190	190	30	66	72	18 3/4	8	16 1/4	17 3/4	30	2 1/2 NPT	491
A8225	225	30	78	84	18 3/4	10	16 1/4	27 3/4	30	2 1/2 NPT	556
A8275	275	36	68	74	21	6 11/16	16 3/8	16 7/8	36	3 NPT	600
A8330	330	36	80	86	21	8 11/16	16 1/4	26 3/4	36	3 NPT	672
A8380	380	36	93	99	21 3/16	9	22 1/4	33 3/4	36	3 NPT	750
A8390	390	42	70 3/4	76 3/4	23 3/8	6	14	18	42	3 NPT	905
A8460	460	42	83 3/4	89 3/4	22 5/16	9 11/16	13 7/8	28	42	3 NPT	1026
A8535	535	42	96	102	22 7/16	9 11/16	13 7/8	41 3/8	42	3 NPT	1141